



STANDON

**For Serial Nos.
790,000 & Higher**
Part No. 4500-435 Rev. A

Operator's Manual

Exmark reserves the right to make changes or add improvements to its products at any time without incurring any obligation to make such changes to products manufactured previously. Exmark, or its distributors and dealers, accept no responsibility for variations which may be evident in the actual specifications of its products and the statements and descriptions contained in this publication.



If your Exmark dealer does not have the Exmark part in stock, Exmark will get the parts to the dealer the next business day or the part will be FREE Guaranteed!! (Some restrictions apply. See your participating Exmark Dealer for details.)

Introduction

CONGRATULATIONS on the purchase of your Exmark StandOn. This product has been carefully designed and manufactured to give you a maximum amount of dependability and years of trouble-free operation.

This manual contains assembly, operating, maintenance, adjustment, and safety instructions for your StandOn.

BEFORE OPERATING YOUR MOWER, CAREFULLY READ THIS MANUAL IN ITS ENTIRETY.

By following the operating, maintenance, and safety instructions, you will prolong the life of your StandOn, maintain its maximum efficiency, and promote safe operation.

If additional information is needed, or should you require trained mechanic service, contact your authorized Exmark equipment dealer or distributor.

All Exmark equipment dealers and distributors are kept informed of the latest methods of servicing and are equipped to provide prompt and efficient service in the field or at their service stations. They carry ample stock of service parts or can secure them promptly for you from the factory.

All Exmark parts are thoroughly tested and inspected before leaving the factory, however, attention is required on your part if you are to obtain the fullest measure of satisfaction and performance.

Whenever you need service, genuine Exmark parts, or additional information, contact an Authorized Service Dealer or Exmark Customer Service and have the model and serial numbers of your product ready.

Figure 1 identifies the location of the model and serial numbers on the product. Write the numbers in the space provided.

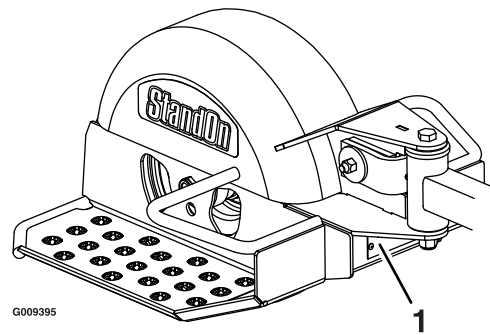

Figure 1

1. Model and serial number location

Model No. _____
Serial No. _____

Contents

Introduction	3
Safety	5
Safety Alert Symbol.....	5
Safe Operating Practices	5
Safety and Instructional Decals	7
Specifications	8
Model Numbers	8
Dimensions.....	8
Tire	8
Setup	9
Assembly Diagram	9
Installing the StandOn Rider to Mower.....	10
Operation	13
Pre-Start.....	13
Operating Instructions	13
Transporting	13
Maintenance	14
Recommended Maintenance Schedule(s)	14
Periodic Maintenance	14
Inspect StandOn	14
Check StandOn for Buildup.....	14
Lubricate Grease Fittings.....	14
Lubricate Caster Wheel Hubs	15
Adjustments	16
Adapter Plate and Tire Adjustment	16

Safety

Safety Alert Symbol

This Safety Alert Symbol (Figure 2) is used both in this manual and on the machine to identify important safety messages which must be followed to avoid accidents

This symbol means: **ATTENTION! BECOME ALERT! YOUR SAFETY IS INVOLVED!**



Figure 2

1. Safety alert symbol

The safety alert symbol appears above information which alerts you to unsafe actions or situations and will be followed by the word **DANGER**, **WARNING**, or **CAUTION**.

DANGER: White lettering / Red background. Indicates an imminently hazardous situation which, if not avoided, **Will** result in death or serious injury.

WARNING: Black lettering / Orange background. Indicates a potentially hazardous situation which, if not avoided, **Could** result in death or serious injury.

CAUTION: Black lettering / Yellow background. Indicates a potentially hazardous situation which, if not avoided, **May** result in minor or moderate injury.

This manual uses two other words to highlight information. **Important** calls attention to special mechanical information and **Note** emphasizes general information worthy of special attention.

Safe Operating Practices

Training

- Read the tractor and StandOn Operator's Manuals and other training material. If the operator(s) or mechanic(s) can not read English it is the owner's responsibility to explain this material to them.
- Become familiar with the safe operation of the equipment, operator controls, and safety signs.
- All operators and mechanics should be trained. The owner is responsible for training the users.

- Never let children or untrained people operate or service the equipment. Local regulations may restrict the age of the operator.
- The owner/user can prevent and is responsible for accidents or injuries occurring to himself or herself, other people or property.
- Only allow the machine operator on the StandOn.

Preparation

- Do Not modify the StandOn.
- Evaluate the terrain to determine what accessories and attachments are needed to properly and safely perform the job. Only use on machines approved by Exmark.
- Wear appropriate clothing including safety glasses, substantial footwear, long trousers, and hearing protection. Do Not operate when barefoot or when wearing open sandals.

CAUTION

The machine that the StandOn attaches to produces sound levels in excess of 85 dBA at the operator's ear and can cause hearing loss through extended periods of exposure.

Wear hearing protection when operating this machine.

- Inspect the area where the equipment is to be used and remove all rocks, toys, sticks, wires, bones, and other foreign objects which can be thrown by the machine and may cause personal injury to the operator or bystanders.

Operation

- Operate only in daylight or good artificial light, keeping away from holes and hidden hazards.
- Stop engine, wait for all moving parts to stop, remove key and engage parking brake whenever you leave the mower.

Slope Operation

Use **Extreme** caution when mowing and/or turning on slopes as loss of traction and/or tip-over could occur. The operator is responsible for safe operation on slopes.

⚠ DANGER

Operating on wet grass or steep slopes can cause sliding and loss of control. Loss of control and/or loss of operator's footing could result in a fall with an arm or leg getting under the mower or engine deck which may result in serious injury, death or drowning.

- **Mow across slopes, never up and down.**
- **Do Not mow slopes when grass is wet.**
- **Do Not mow near drop-offs or near water.**
- **Do Not mow slopes greater than 20 degrees.**
- **Reduce speed and use extreme caution on slopes.**
- **Avoid sudden turns or rapid speed changes.**

Wait for all movement to stop before adjusting, cleaning or repairing.

- Use care when checking blades. Wrap the blade(s) or wear gloves, and use caution when servicing them. Only replace damaged blades. Never straighten or weld them.
- Keep all guards, shields and all safety devices in place and in safe working condition.
- Check all bolts frequently to maintain proper tightness.
- Frequently check for worn or deteriorating components that could create a hazard.
- All replacement parts must be the same as or equivalent to the parts supplied as original equipment.

- See inside the back cover to determine the approximate slope angle of the area to be mowed.
- Remove or mark obstacles such as rocks, tree limbs, etc. from the mowing area. Tall grass can hide obstacles.
- Watch for ditches, holes, rocks, dips and rises that change the operating angle, as rough terrain could overturn the machine.
- Avoid sudden starts when mowing uphill because the mower may tip backwards.
- Be aware that operating on wet grass, across steep slopes or downhill may cause the mower to lose traction. Loss of traction to the drive wheels may result in sliding and a loss of braking and steering.
- Always avoid sudden starting or stopping on a slope. If tires lose traction, disengage the blades and proceed slowly off the slope.
- Follow the manufacturer's recommendations for wheel weights or counter weights to improve stability.
- Always install and remove the StandOn as instructed. Failure to do so will cause a reduction in stability or traction.

Maintenance and Storage

- Disengage drives, set parking brake, stop engine and remove key or disconnect spark plug wire.

Safety and Instructional Decals

- Keep all safety signs legible. Remove all grease, dirt and debris from safety signs and instructional labels.
- Replace all worn, damaged, or missing safety signs.
- When replacement components are installed, be sure that current safety signs are affixed to the replaced components.
- If an attachment or accessory has been installed, make sure current safety signs are visible.
- New safety signs may be obtained from your authorized Exmark equipment dealer or distributor or from Exmark Mfg. Co. Inc.
- Safety signs may be affixed by peeling off the backing to expose the adhesive surface. Apply only to a clean, dry surface. Smooth to remove any air bubbles.
- Familiarize yourself with the following safety signs and instruction labels. They are critical to the safe operation of your Exmark commercial mower.



1-303517

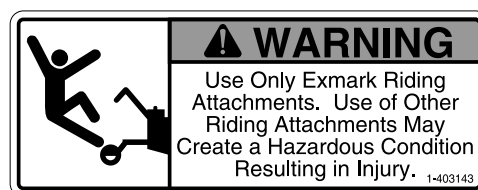

1-403143



103-9141

Specifications

Specifications

Model Numbers

Serial Nos: 790,000 and Higher

STANDON

Dimensions

Length	Width	Height	Weight
35.4 inches (89.9 cm)	18.5 inches (47.0 cm)	14.9 inches (37.9 cm)	50 lb (23kg)

Tire

	Tread	Size
Semi-Pneumatic Tire	Smooth	11 x 4.00-5

For Operators over 250 lb it is recommended to use pneumatic tire assembly P/N 103-3798.

Setup

Assembly Diagram

Item	Quantity	Description
1	8	Nut, Nyloc 3/8-16 Flg
2	2	Plate, Back-Up
3	2	Plate, Adapter
4	8	Screw, HH 3/8-16 x 1 1/4
5	1	Asm, Frame Pull W/Decals
6	1	Asm, Pull Arm W/Brgs
7	1	Guard, Top
8	1	Screw, HH 3/8-16 x 4 3/4
9	1	Nut, Hex Flg-Side Lock 3/8-16
10	1	Asm, Sulky Frame W/Decals
11*	2	Decals, Replacement (Turf Tracer and Viking Hydro Only)
12	1	Washer, Spring Disc

*Not shown in illustration

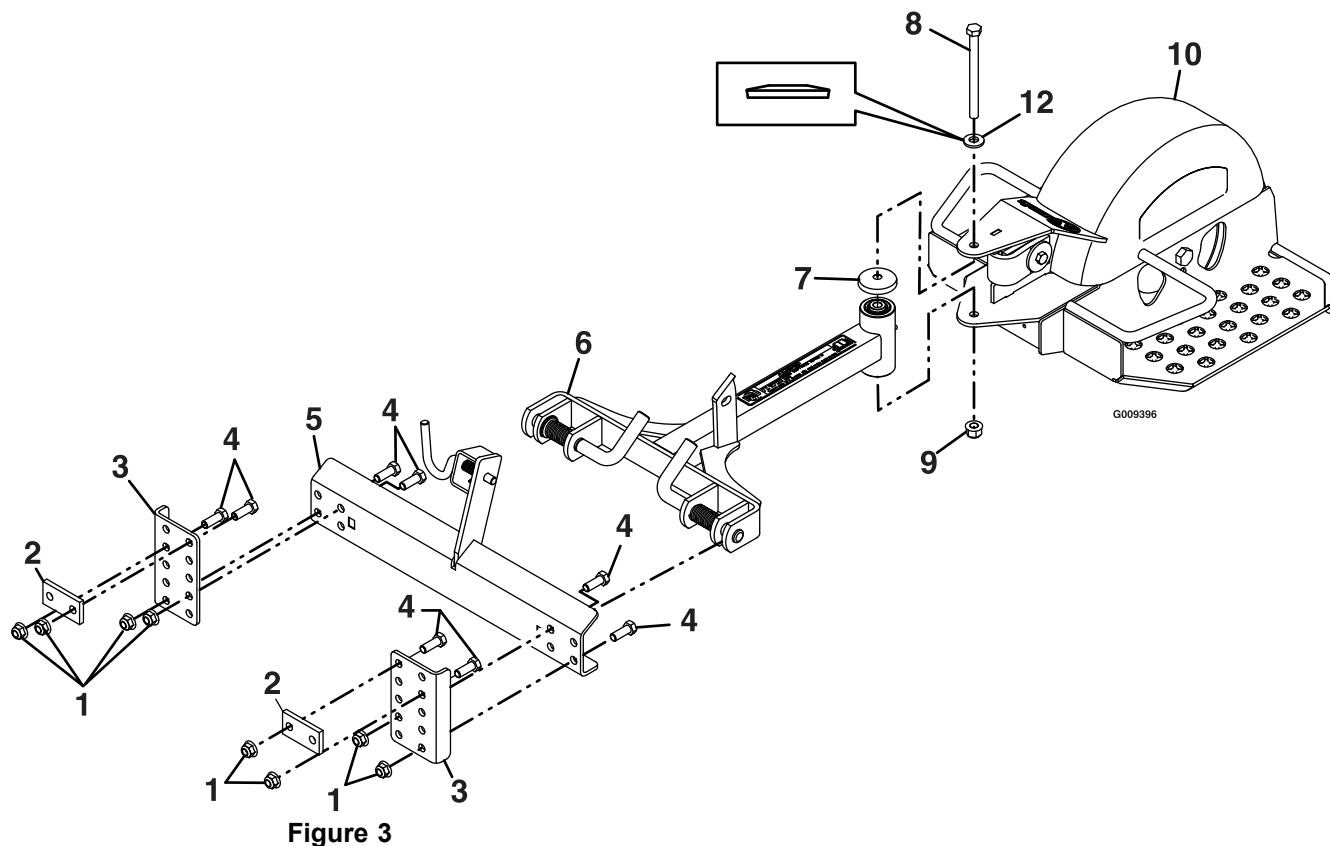

Setup

Installing the StandOn Rider to Mower

Mounting the Pull Frame

1. Locate the pull frame and two adapter plates. Install the pull frame to the adapter plates using four 3/8-16 x 1 1/4 inch hex capscrews and four 3/8-16 inch nyloc nuts as shown in Figure 4.

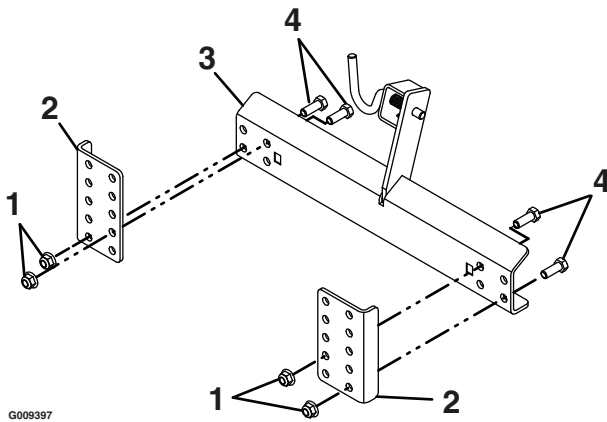

Figure 4

1. 3/8-16 inch nyloc nuts
2. Adapter plate
3. Pull frame
4. 3/8-16 x 1 1/4 inch hex capscrews

2. Mounting the pull frame assembly to the engine deck:

A. For Turf Tracer and Viking Hydro Units Only:

- a. If your unit has four holes drilled in the rear surface of the engine deck proceed to step c; if not, continue with step b.
- b. Remove the two decals on the lower rear surface of the engine deck (see Figure 5).

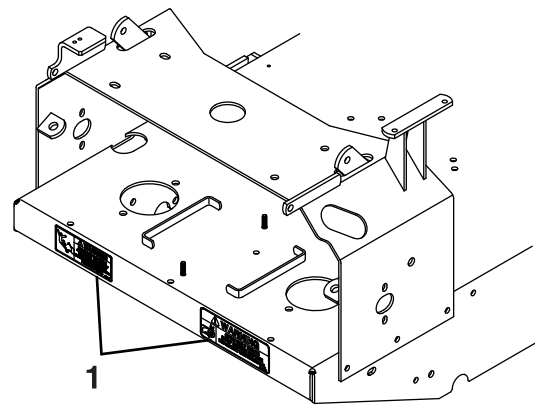

Figure 5

1. Remove these two decals.

- c. Center the adapter plates on the lower rear surface of the mower engine deck and mark the four hole locations shown in Figure 6. Drill four 0.407 inch diameter holes through the engine deck at the marked locations.

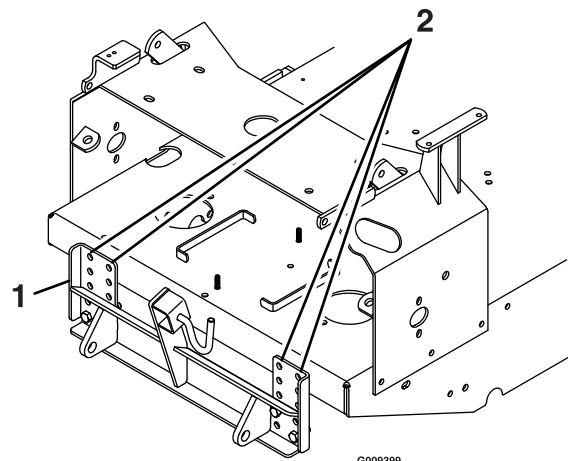

Figure 6

1. Pull frame and adapter plate assembly
2. Mark and drill two holes each side.

- d. Apply the two replacement decals to the engine deck between the mounting holes (see Figure 7).

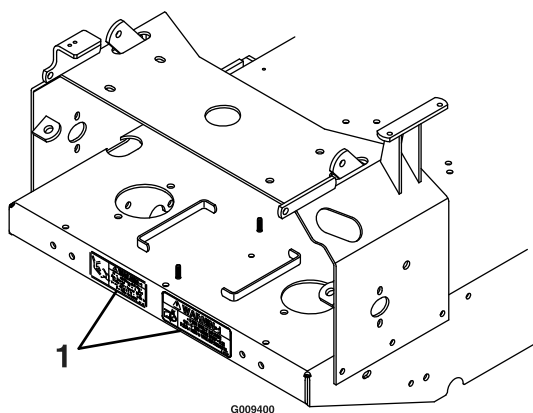

Figure 7

1. Replacement decals

- e. Align the pull frame and adapter plate assembly to the rear surface of the engine deck. Measure the distance from the bottom of the pull frame to the ground. Choose the mount holes that will attain a distance approximately 8 inches (20 cm).

Install the mount brackets to the mower engine deck using two 3/8-16 x 1 1/4 inch hex capscrews, two back-up plates, and two 3/8-16 inch nyloc nuts as shown in Figure 8).

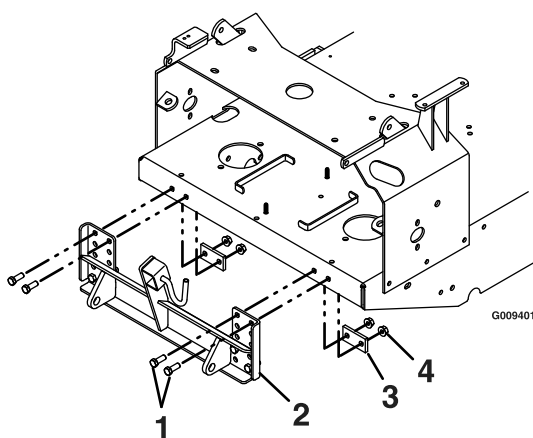

Figure 8

1. 3/8-16 x 1 1/4 inch hex capscrews
2. Pull frame and adapter plate assembly
3. 3/8-16 inch nyloc nuts
4. Back-up plates

B. For Turf Tracer HP and Metro HP Units:

- a. Align the pull frame and adapter plate assembly to the rear surface of the engine deck. Measure the distance from the bottom of the pull frame to the ground.

Choose the mount holes that will attain a distance of approximately 8 inches.

- b. Install the adapter plates to the mower engine deck using two 3/8-16 x 1/4 inch hex capscrews and two 3/8-16 inch flanged nyloc nuts as shown in Figure 9.

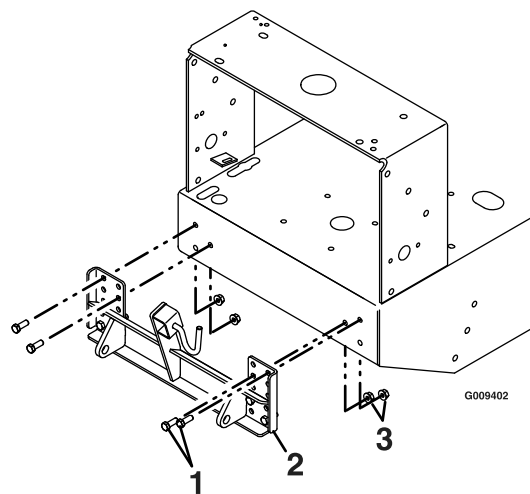

Figure 9

1. 3/8-16 x 1/4 inch hex capscrews
2. Pull frame and adapter plate assembly
3. 3/8-16 inch flanged nyloc nuts

Mounting the Pull Arm and Platform

For Turf Tracer, Turf Tracer HP, Metro HP, and Viking Hydro Units:

1. Locate the pull arm assembly. Align the pull arm assembly with the pull frame as shown in Figure 10. Squeeze the quick connect pins on the pull arm assembly and attach the pull arm assembly to the pull frame.

Setup

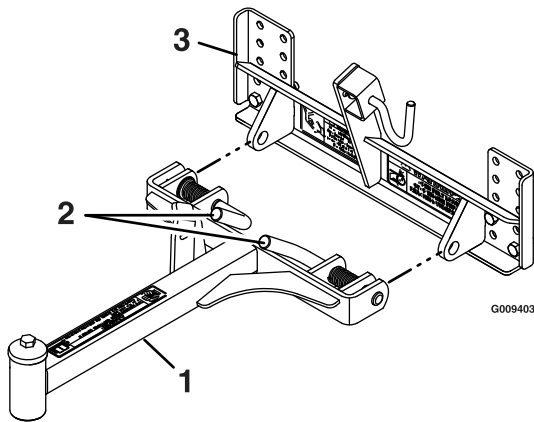

Figure 10

- 1. Pull arm assembly
- 2. Quick connect pins
- 3. Pull frame

Important: For optimal performance, the StandOn pull arm top surface should be horizontal to the ground surface.

To obtain a position as close to horizontal as possible, the adjustment brackets and the platform wheel can be repositioned (see **Adapter Plate and Tire Adjustment** section in Maintenance).

-
- 2. Remove the 3/8-16 x 4 3/4 inch hex capscrew, spring disc washer, and 3/8-16 inch hex flange side lock nut from the pivot hub.
 - 3. Locate the sulky frame assembly and align with the pull arm assembly. Re-install the 3/8-16 x 4 3/4 inch hex capscrew, spring disc washer, and 3/8-16 inch hex flange side lock nut removed in step 1 as shown in Figure 11. Torque to 35-38 ft-lb (47-52 N-m).

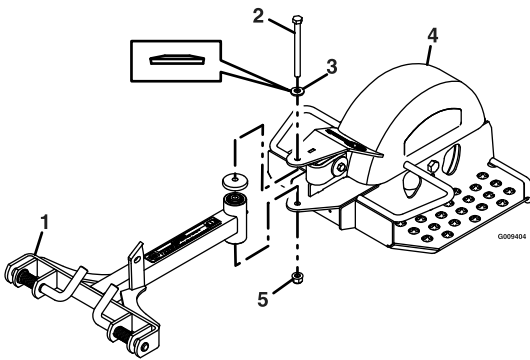

Figure 11

- 1. Pull frame assembly
- 2. 3/8-16 x 4 3/4 inch hex capscrew
- 3. Spring disc washer
- 4. Sulky frame assembly
- 5. 3/8-16 inch hex flange side lock nut

Operation

Note: Determine the left and right sides of the machine from the normal operating position.

Pre-Start

1. Make sure you understand the controls, their locations, their functions, and their safety requirements.
2. Practice operating the machine without the StandOn until familiar with the controls.
3. Practice operating the machine with the StandOn attached on large, open, level terrain with no obstacles present before use. the StandOn will affect the machine operation, especially on slopes, when turning, and when stopping.
4. Ensure the pull arm assembly is securely connected to the pull frame.
5. For Metro HP Units: Wheel drive belt tension may need adjustment. Refer to the machine Operator's Manual for adjustment instructions.
6. For operation of StandOn with Metro HP, Viking Hydro, and Turf Tracer HP on hilly terrain, front weight kit accessory, P/N 103-2637, is recommended.
7. For operators over 250 lb, it is recommended to use pneumatic tire assembly, P/N 103-3798.

1. Use care when turning to ensure that you Do Not swing yourself and the sulky into obstacles.
2. When turning, lean forward and toward the direction of the turn to help in keeping balance.

Transporting

Transporting a Unit

Place the StandOn in the transport position when loading a unit on a trailer, unloading a unit from a trailer, or operating in reverse (see Figure 12).

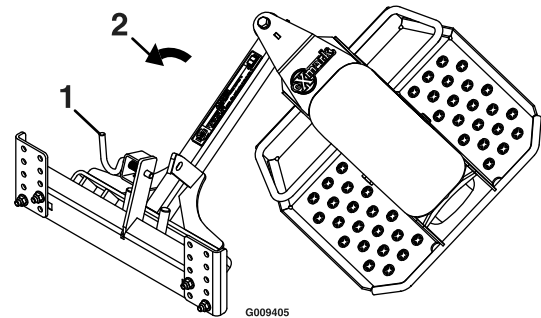

Figure 12

1. Latch pin
2. Rotate platform into transport position and lock with latch pin

Operating Instructions

Mowing

⚠ DANGER

If the StandOn rotates beyond 90°, there is a potential crushing hazard. Rapid rotation beyond 90° can cause the StandOn to jackknife into the mower engine deck and cause serious injury.

- Dismount the StandOn and place in transport position before operating in reverse.
- Reduce speed when making sharp turns and operating on slopes.

Maintenance

Note: Determine the left and right sides of the machine from the normal operating position.

⚠ WARNING

While maintenance or adjustments are being made, someone could start the engine. Accidental starting of the engine could seriously injure you or other bystanders.

Remove the key from the ignition switch, engage parking brake, and pull the wire(s) off the spark plug(s) before you do any maintenance to the unit or StandOn. Also push the wire(s) aside so it does not accidentally contact the spark plug(s).

Recommended Maintenance Schedule(s)

Maintenance Service Interval	Maintenance Procedure
Before each use or daily	<ul style="list-style-type: none">• Inspect the StandOn.• Check for dirt/mud buildup between tire and fender.
Every 25 hours	<ul style="list-style-type: none">• Grease pull arm pivot.
Yearly	<ul style="list-style-type: none">• Grease caster wheel hub.• Lubricate the caster wheel hubs.

Periodic Maintenance

Inspect StandOn

Service Interval: Before each use or daily

1. Stop engine, wait for all moving parts to stop, and remove key. Engage parking brake.
2. Inspect for loose hardware. Tighten any loose hardware.
3. Inspect for wear or damage daily. Replace or repair worn parts as needed before operating.

Check StandOn for Buildup

Service Interval: Before each use or daily

Check for dirt/mud buildup between tire and fender. Remove buildup before operating.

Lubricate Grease Fittings

Note: See chart for service intervals.

1. Stop engine, wait for all moving parts to stop, and remove key. Engage parking brake.
2. Lubricate fittings with NGLI grade #2 multi-purpose gun grease.

Refer to the following chart for fitting locations and lubrication schedule.

Lubrication Chart			
Fitting Locations	Initial Pumps	Number of Places	Service Interval
1. Pull Arm Pivot	1-2	1	Yearly
2. Caster Wheel Hub	0*	1	Yearly

Lubricate Caster Wheel Hubs

Service Interval: Yearly

1. Stop engine, wait for all moving parts to stop, and remove key. Engage parking brake.

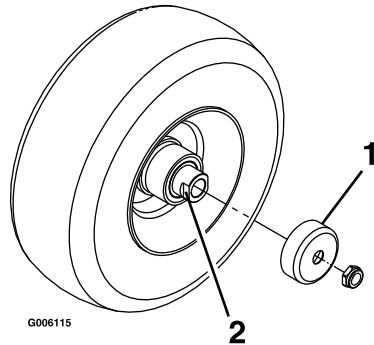

Figure 13

1. Seal guard
 2. Spacer nut with wrench flats
-
2. Remove the caster wheel from the sulky frame.
 3. Remove seal guards from the wheel hub.
 4. Remove one of the spacer nuts from the axle assembly in the caster wheel. Note that thread locking adhesive has been applied to lock the spacer nuts to the axle. Remove the axle (with the other spacer nut still assembled to it) from the wheel assembly.
 5. Pry out seals, and inspect bearings for wear or damage and replace if necessary.
 6. Pack the bearings with a NGLI grade #1 multi-purpose grease.
 7. Insert one bearing, one new seal into the wheel.

Note: Seals (Exmark PN 103-0063) must be replaced.
 8. If the axle assembly has had both spacer nuts removed (or broken loose), apply a thread locking adhesive to one spacer nut and thread onto the axle with the wrench flats facing outward. Do Not thread spacer nut all of the way onto the end of the axle. Leave approximately 1/8 inch (3 mm) from the outer surface of the spacer nut to the end of the axle inside the nut.
 9. Insert the assembled nut and axle into the wheel on the side of the wheel with the new seal and bearing.
 10. With the open end of the wheel facing up, fill the area inside the wheel around the axle full of NGLI grade #1 multi-purpose grease.

11. Insert the second bearing and new seal into the wheel.
12. Apply a thread locking adhesive to the second spacer nut and thread onto the axle with the wrench flats facing outward.
13. Torque the nut to 75-80 in-lb (8-9 N-m), loosen, then re-torque to 20-25 in-lb (2-3 N-m). Make sure axle does not extend beyond either nut.
14. Reinstall the seal guards over the wheel hub and insert wheel into the sulky frame. Reinstall caster bolt and tighten nut fully.

Important: To prevent seal and bearing damage, check the bearing adjustment often. Spin the caster tire. The tire should not spin freely (more than 1 or 2 revolutions) or have any side play. If the wheel spins freely, adjust torque on spacer nut until there is a slight amount of drag. Reapply thread locking adhesive.

Adjustments

Adapter Plate and Tire Adjustment

Important: For optimal performance, the StandOn pull arm top surface should be horizontal to the ground surface.

To obtain a horizontal pull arm, the adapter plates and the platform wheel can be repositioned (see Figure 14).

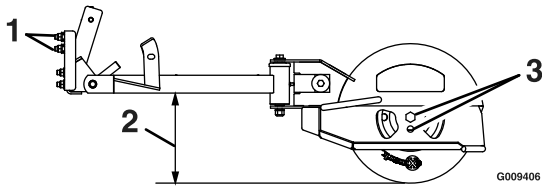

Figure 14

1. Adapter plates can be moved to adjust height position
2. Pull arm should be horizontal to ground
3. Wheel can be mounted in either hole for height adjustment

Note: To achieve more ground clearance for higher cutting heights, raise the platform by using the lower wheel adjustment hole and corresponding adapter plate holes.

Exmark Commercial Attachments and Accessories

1 Year Limited Warranty

Conditions and Products Covered

Exmark Mfg. Co. Inc. and its affiliate, Exmark Warranty Company, pursuant to an agreement between them, jointly warrant on the terms and conditions herein, that we will repair, replace or adjust any part on these products and found by us (in the exercise of our reasonable discretion) to be defective in factory materials or workmanship for a period of one year.

This warranty applies to Exmark commercial attachments and accessories sold in the U.S. or Canada. This warranty may only be assigned or transferred to a second (or third) owner by an authorized Exmark dealer. The warranty period commences upon the date of the original retail purchase.

Warranty Exceptions

- Bags, Belts and Tires

Warranty Period

90 days

This warranty only includes the cost of parts and labor.

Items and Conditions Not Covered

This warranty does not cover the following:

- Pickup and delivery charges to and from any authorized Exmark Service Dealer.
- Any damage or deterioration due to normal use, wear and tear, or exposure.
- Cost of regular maintenance service or parts, such as filters, fuel, lubricants, tune-up parts, and adjustments.
- Any product or part which has been altered or misused or required replacement or repair due to normal wear, accidents, or lack of proper maintenance.
- Any repairs necessary due to use of parts, accessories or supplies, including gasoline, oil or lubricants, incompatible with the attachment or accessory or other than as recommended in the operator's manual or other operational instructions provided by Exmark.

All warranty work must be performed by an authorized Exmark Service Dealer using Exmark approved replacement parts.

Instructions for Obtaining Warranty Service

The product must be registered with original proof of purchase by an Exmark Service Dealer before obtaining any warranty service.

Contact any Exmark Service Dealer to arrange service at their dealership. To locate a dealer convenient to you, access our website at www.exmark.com. U.S. or Canada customers may also call 402-223-6375.

If for any reason you are dissatisfied with the Service Dealer's analysis or with the assistance provided, contact us at:

Exmark Customer Service Department
The Exmark Warranty Company
2101 Ashland Avenue
Beatrice, NE 68310
402-223-6375 or
service@exmark.com

Owner's Responsibilities

The Exmark attachment or accessory, including any defective part, must be returned to an authorized Exmark service dealer within the warranty period. This warranty extends only to commercial attachments and accessories operated under normal conditions. You must read the operator's manual. You must also properly service and maintain your Exmark product as described in the operator's manual or other operational instructions provided by Exmark. Such routine maintenance, whether performed by a dealer or by you, is at your expense.

General Conditions

The sole liability of Exmark and Exmark Warranty Company with respect to this warranty shall be repair or replacement of defective components as set forth herein. **Neither Exmark nor Exmark Warranty Company shall be liable for any incidental or consequential loss or damage.**

Such damages include but are not limited to:

- Expenses related to gasoline, oil or lubricants.
- Travel time, overtime, after hours time or other extraordinary repair charges or charges relating to repairs or replacements outside of normal business hours at the place of business of the authorized Exmark Service Dealer.
- Rental of like or similar replacement equipment during the period of any warranty, repair or replacement work.
- Any telephone or telegram charges or travel charges.
- Loss or damage to person or property other than that covered by the terms of this warranty.
- Any claims for lost revenue, lost profit or additional cost as a result of a claim of breach of warranty.
- Attorney's fees.

No Claim of breach of warranty shall be cause for cancellation or rescission of the contract of sale of any Exmark attachment or accessory.

All implied warranties of merchantability (that the product is fit for ordinary use) and fitness for use (that the product is fit for a particular purpose) are limited to the duration of the express warranty.

Some states do not allow exclusions of incidental or consequential damages, or limitations on how long an implied warranty lasts, so the above exclusions and limitations may not apply to you.

This warranty gives you specific legal rights, and you may also have other rights which vary from state to state.

Service Record

Date:	Description of Work Done:	Service Done By:

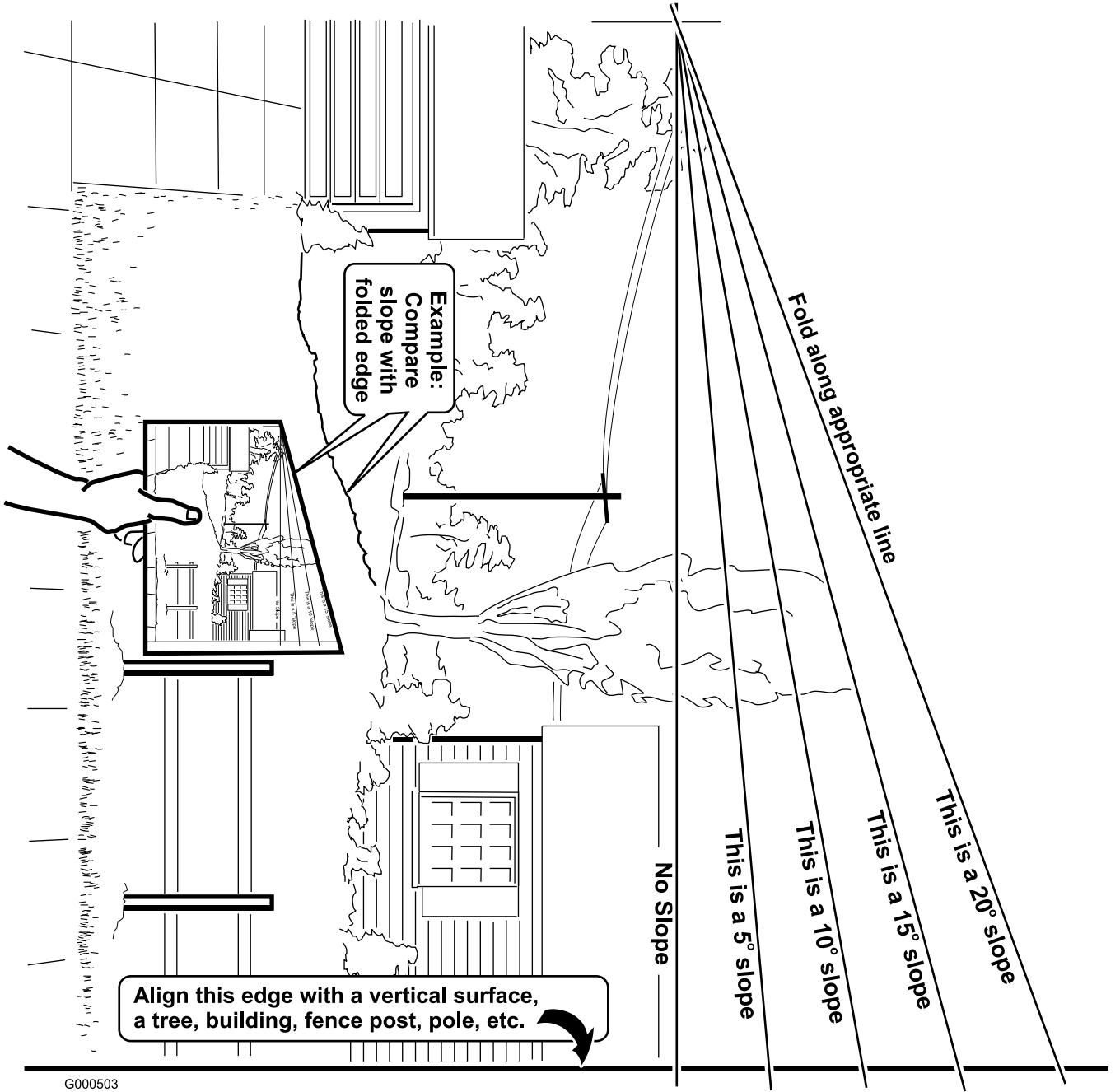

G000503

SEE EXMARK'S COMPLETE LINE OF ACCESSORIES AND OPTIONS

MID-MOUNT RIDING ACCESSORIES AND OPTIONS

CUSTOM RIDE SEAT SUSPENSION SYSTEM	OPERATOR CONTROLLED DISCHARGE
FULL SUSPENSION SEAT	ROLL OVER PROTECTION SYSTEM (ROPS)
DECK LIFT ASSIST KIT	SUN SHADE
HITCH KIT	TRASH CONTAINER
LIGHT KIT	TURF STRIPER
12V POWER PORT	ULTRA VAC COLLECTION SYSTEM
MICRO-MULCH SYSTEM	ULTRA VAC QUICK DISPOSAL SYSTEM

OUT-FRONT RIDING ACCESSORIES AND OPTIONS

CUSTOM RIDE SEAT SUSPENSION SYSTEM	SNOW BLADE
DUAL-TAIL WHEEL	SNOWBLOWER
FLOOR PAN EXTENDER	SUN SHADE
HITCH KIT	TRASH CONTAINER
LIGHT KIT	ULTRA VAC COLLECTION SYSTEM
MICRO-MULCH SYSTEM	ULTRA VAC QUICK DISPOSAL SYSTEM
ROLL OVER PROTECTION SYSTEM (ROPS)	WEATHER CAB

WALK-BEHIND ACCESSORIES AND OPTIONS

GRASS CATCHER	TURF STRIPER
MICRO-MULCH SYSTEM	STANDON

Place Model No. and Serial No.
Label Here (Included in the Literature
Pack) or Fill in Below

Model No. _____

Serial No. _____

Date Purchased _____

© 2008 Exmark Mfg. Co., Inc.
Industrial Park Box 808
Beatrice, NE 68310
All Rights Reserved

Part No. 4500-435 Rev. A
(402) 223-6300
Fax (402) 223-5489
Printed in the USA

